

Application Alley

PARTNER | SOLVE | DELIVER

Switching Low μV Signals

Reed Relays Capable of Switching Low Micro Volts Signals



Custom
Engineered
Solutions for
Tomorrow

Introduction

As electronic components continue their downward size spiral, their capabilities are ever increasing. Accompanying this, chip line widths are narrower than ever giving rise to unwanted small voltage or leakage currents, which may give rise to signal errors. Several applications have arisen requiring the capability of discerning very low signal levels and the need to make the measurements of these low level voltages and currents.

Scanner systems, Data Acquisition Systems, DMMs, Multifunctional Instruments, and ATE systems represent a few electronic systems requiring the need for low voltage measurements. These systems generally require a means of switching their small signals. The needs vary, but most require the following parameters for their system switching requirements:

1. Insulation resistance typically 1×10^{13} / or higher
2. Low switching offset voltages (on the order of 1 to 10 μV),³.
3. Capability of switching a minimum of 200 Volts but preferably up to 1000 volts
4. Isolation voltages of 2500 Volts or greater between all points.
5. Low capacitance across the switching elements typically less than 0.3 pf but preferably lower.
6. Long life hundreds of millions of operations expected.

Switching Selection Process

Selecting a semiconductor switching device is the preferred ideal approach. However, semiconductors don't have very high insulation resistance – typically 1×10^9 or less; their ability to switch high voltages is limited; standing off 2500 volts or greater is very limited; and their junction capacitance can be very high.

An electromechanical relay could be a viable option if it wasn't for its limited life and not meeting several of the other above parameters.

That leaves the best solution the Reed Relay. Here all the above criteria are met with one possible exception – the switching of low offset voltages. The Reed Relay has two critically needed items for its functionality that affect the offset voltage: relay coil needed to produce the magnetic field that closes the contacts ; and the reed contacts themselves must be ferromagnetic a nickel/iron alloy.

When a voltage is applied to the coil it produces heat. The nickel/iron reed leads, when soldered to the copper lands of a PCB, produce an excellent thermocouple generating over 1 millivolt (mV) at 20°C. For each a 1°C change they, will produce on the order of 60 microVolts (2V); or a 0.1°C change can generate up to 10 μV .

However, there is hope. Reed Relays can be specially designed to minimize that thermal offset voltage. Below we will show you how we at Standex-Meder accomplish this. Generally there are two types of switching configurations used in the above applications:

- A single pole single throw Reed Relay
- A double pole single throw Reed Relay

The single pole Reed Relays are most often used in the input of DMMs where they are required to standoff the entire usable voltage range; have the ability to carry the entire current range; and not affect or influence the resistance readings at their low or high ranges. This can be particularly challenging when DMMs require voltage standoffs in excess of 1000 Volts and the ability to measure low voltages in the micro-volt range. The Reed Relay is the only technology capable of handling these ranges without influencing the outcome of the readings.

The Two Pole Reed Relay

Looking at the schematic of the two pole Reed Relay from a thermocouple standpoint can show the scope, nature and problems involved in passing low voltage signals through a relay (See Figure 1 Below).

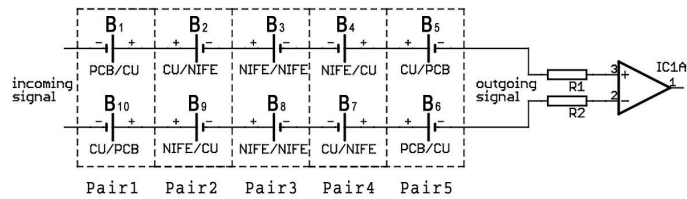

Figure 1. Two pole Reed Relay thermocouple schematic.

Essentially, users of two pole Reed Relays use the relay in a differential circuit configuration whereby the input signals, when switched are sent into the dual inputs of an amplifier. The important criteria as it relates to the Reed Relay, is that the sum of all the thermocouples must be at or near zero, or

Equation 1. $B_1 + B_2 + B_3 + B_4 + B_5 + B_6 + B_7 + B_8 + B_9 + B_{10} = 0$

Keep in mind, a thermocouple is generated at any junction where two or more metals are joined together. They do not need to be different metals. Looking at B1 thru B10 as a series circuit one can see that the five pairs shown are opposite in polarity from a current flow standpoint. Here the ‘B’ denotes the small voltage produced by the thermocouple generating the net effect of a small battery. PCB represents the printed circuit board, Cu – copper lead pins of the relay, and NiFe – the nickel/iron Reed Switch leads. Looking at the pairs individually:

Pair 1. and Pair 5. Generally the PCBs have copper lands. So here the thermocouples are copper to copper. Theoretically copper to copper is a thermocouple but its voltage generation

is small. However, it is important to make sure there are no significant heat sources near these junctions, thereby minimizing the generation of any offset voltages from these thermocouples. So we make the following two assumptions: $B_1 + B_{10} = 0$ and $B_5 + B_6 = 0$.

Pair 3. Again there can be a voltage generated by the NiFe to NiFe thermocouple but it will generally be small. These junctions generally reside in the inside center of the coil and should see a consistent temperature. Therefore, we don’t see any major net offset from B3 and B8. Therefore, $B_3 + B_8 = 0$.

Pair 2. And Pair 4. These thermocouples are the key thermocouples that we must pay very close attention. Namely, NiFe to Cu represents a very strong thermocouple and will generate sufficient voltages that will swamp out small incoming signals going through the relay. Generating over 1 mV at 20°C will clearly swamp out any signals in the low μV range. B2 and B9 are opposite in polarity $B_2 + B_9 \neq 0$; and by the same argument $B_4 + B_7 \neq 0$ as well.

Taking the above points into consideration, we can simplify Figure 1. (See Figure 2.).

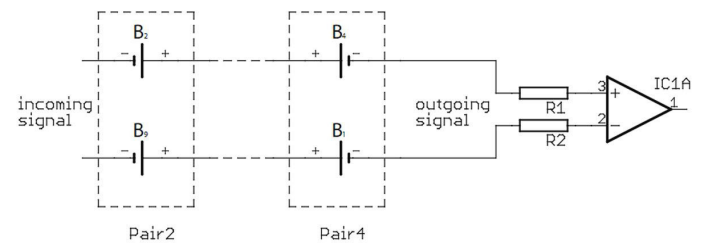

Figure 2. Simplified thermal path for a two pole Reed Relay.

Pairs B2 - B9, and B4 – B7 are at the ends of the relay and are internal to the relay. Since these thermocouples have such large voltage offsets, there is only one way to minimize them, and that is to make B2 and B9 exist at identical temperatures, and the same for B4 and B7.

The coil, once a voltage is applied across it, becomes a heat generator and this heat becomes the main obstacle we need to overcome.

This heat generation will make itself felt at all four of these thermocouples. However, we have devised a special way of developing an isothermal junction for the thermocouple pairs of B2 - B9 and B4 - B7. This approach accomplishes the following: $B2 + B9 = 0$ and $B4 + B7 = 0$. Therefore, when a very low voltage signal is switched through the two pole Reed Relay, there will be a negligible effect from the thermocouples shown in Figure 1. Insuring signal integrity.

Thermally Compensated Low Offset Voltage Reed Relays

The key to an isothermal junction is its ability to efficiently conduct heat. The fundamental law of heat conduction is given by Equation 2.

Equation 2. $dQ/dt = -kA(dT/dx)$

Here dT/dx is the temperature gradient, dQ/dt is the time rate of heat transfer, A is the cross-sectional area, and k is the thermal conductivity.

The larger k and A are, the quicker the heat is transferred making any heat changes appear isothermal in nature. The smaller dx is the shorter the distance the heat has to transfer, therefore, heat transfer will occur faster. These are all key factors in developing an isothermal junction.

Table of Thermal Conductivities (kcal/hr m °C)	
Material	Thermal Conductivity
Silver	158
Copper	149
Lead	13
Nickel	35
Iron	28
Tin	26
Aluminum	79
Beryllia (BeO)	84
Alumina (Al ₂ O ₃)	52

Table 2. Thermal Conductivity listing of some solids.

As shown in Table 1, the heat conductivities vary widely with silver and copper topping the list. Most metals are very good heat conductors; however, they also conduct electricity. The thermocouples we are trying to make isothermal must be isolated from each other electrically, which essentially eliminates all metals. Fortunately some solids have the characteristic of being very good heat conductors while offering very good electrical isolation. Two of the most popular heat conducting insulators are listed in the above table: beryllia and alumina. As one can see the beryllia and alumina have better heat conductivity than many metals, but offer excellent insulation resistance and dielectric withstand voltage.

We have successfully used both beryllia and alumina in reducing thermal offset voltages below 1 μVolt with 100% duty cycle. We have used beryllia and alumina in thin wafer form with metallization on both sides of the wafer to make connections (See Figure 3). Two wafers are used on both ends of the relay internally. The connections are made to each side of the wafer bringing the B2 - B9 pair and B4 - B7 pair together from a heat conductivity standpoint, but they maintain their isolation by the thickness of the wafer. These wafers will easily withstand greater than 2500 Volts DC and have insulation resistances greater than 1×10^{13} ohms.

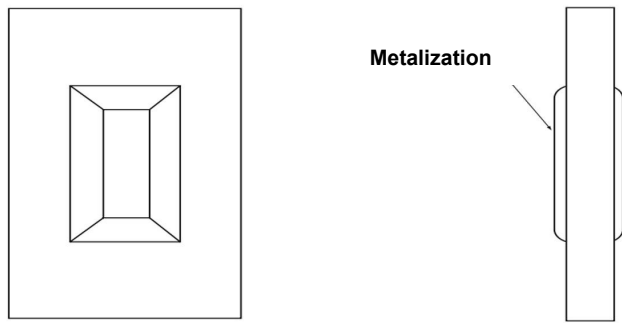

Figure 3. Isothermal wafer made of either alumina or beryllia.

The Single Pole Reed Relay

Looking at the single pole Reed Relay, one would think that with one less switching point, controlling the thermal offset voltage would be much easier. As it turns out this is not the case. Looking at Figure 4 can give some insight.

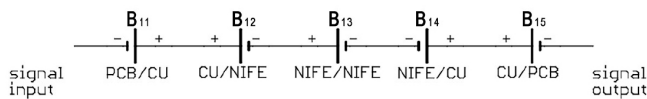

Figure 4. Single pole Reed Relay thermocouple schematic.

B11 through B15 has a similar look to one of the poles shown in the two pole schematic in Figure 1. And we can make similar assumptions about B11, B13 and B15 as we had done with the two pole relay. With that in mind we have simplified Figure 4 and have come up with Figure 5.



Figure 5. Simplified thermal path for a single pole Reed Relay thermocouple schematic.

In Figure 5 we now only have to deal with two thermocouples, which seems simple enough;

however, the problem is that these two thermocouples are on opposite sides of the relay. They are spatially not close together. So using wafers to solve the thermal problem as we did with the two pole Reed Relay can not be done. We have solved the problem with two different approaches. The first approach was similar to the two pole solution. Essentially, we used alumina for the entire base of the relay. Basically this represents a large isothermal mass to keep both ends of the relay at the same temperature. Another key element was to make the relay length as short as possible. Both of these elements were captured nicely in our CR Series, which is only 8 mm long. (See Figure 6).

The second approach is to cleverly use two Reed Switches in series, where their com-

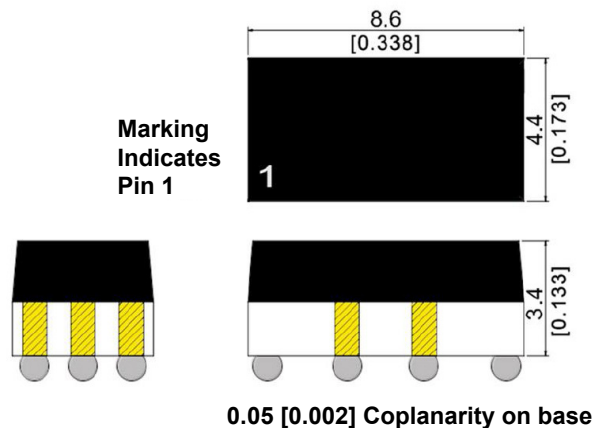

Figure 6. CR Series has excellent low thermal offset voltage characteristics.

mon ends are welded together. With the Reed Switches lying in parallel, this places the ends of the two switches back on the same side of the relay allowing us to compensate for the thermal offset voltage using the isothermal wafer approach (see Figure 7).

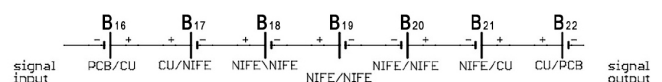

Figure 7. Single pole Reed Relay schematic using two reed switches.

Shown in the schematic in Figure 7 are the seven thermocouples, B16 through B22. B19 is the thermocouple arising from the welded ends of the two Reed Switches. So again, from the analyses above we can simplify Figure 7 as shown in Figure 8.

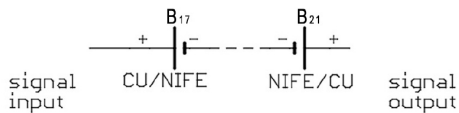

Figure 8. Simplified schematic of a single pole Reed Relay using two switches.

In Figure 8, the schematic looks very similar to Figure 6; however, in Figure 8 the thermocouples are on the same end of the relay allowing the use of an isothermal wafer, rather than having to use a large ceramic (alumina) base to establish low thermal offset voltages. The closer the thermocouples we are trying to compensate, the better the chances of producing very low thermal offset voltages.

Latching Reed Relays

Latching Reed Relays use a biasing magnet to close and open the reed contacts. Generally a 2ms pulse supplied at the relay nominal voltage is enough to change the state of the relay. Therefore, heat generated when closing and opening the relay contacts is minimal and resulting in minimal thermal offset voltage. Latching Reed Relays do require a magnetic polarity reversal when changing the state of the contacts. This can be done using two coils, or reversing the polarity of one coil each time the contact state is changed. In the former case it adds more cost to the relay; and in the latter case more circuitry is required to change the polarity for each contact state change. To accomplish a latching Reed Relay one also needs special wide differential Reed Switches, which may need to be sorted, and limiting some Reed Switch parameters. All things considered it can

be a very good ultra low thermal offset voltage Reed Relay.

Measuring Very Low Offset Voltages

A simple but confined test procedure is used to measure the offset voltages produced by thermal gradients across the input to output of a given set of relay contacts; or in the case of a double set of reed contacts, the differential offset voltage is measured.

Single Pole Relay Measurement

Measurement of the thermal offset voltage across the contacts of a single Reed Switch, for best results, should be performed in an insulated box, free of any air movement at ambient temperature. The leads to power the coil and the leads to make the low voltage offset measurement should be fed into the box minimizing any potential airflow. We typically make the low voltage measurement with a Keithley Instrument Model No. 2182, which should be allowed to warm up for a minimum of one hour (See Figure 9).

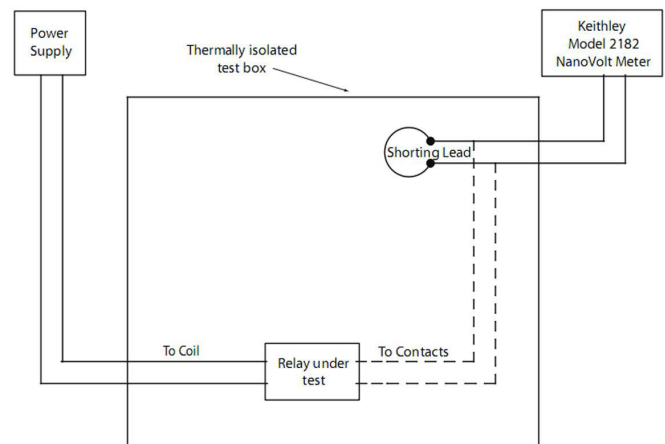

Figure 9. Single pole relay thermal offset voltage measurement setup.

After instrument warm-up, the output leads should be connected to a low mass copper shorting lead for 10 minutes inside the box. After 10 minutes the meter should be adjusted for 0 voltage across its leads, then disconnected from the shorting pins and connected directly across the relay contact leads. The low mass shorting leads are important, since they represent the low mass connections eventually made to the user's PCB. Larger mass shorting leads can compromise the internal thermal compensation in the relay. This is also true for the Keithley leads connections to the relay.

Allow 5 minutes for the test system and the relay to all come to thermal equilibrium. Then apply the nominal voltage across the relay coil. Once applied, the contacts close showing an offset voltage that should be at or very close to zero. If not, it may indicate the relay was not in thermal equilibrium or a thermal offset voltage material mismatch may exist.

Allow 5 minutes for the test system and the relay to all come to thermal equilibrium. Then apply the nominal voltage across the relay coil. Once applied, the contacts close showing an offset voltage that should be at or very close to zero. If not, it may indicate the relay was not in thermal equilibrium or a thermal offset voltage material mismatch may exist.

The Keithley meter has a millivolt output allowing one to directly monitor the offset voltage change on a continuous basis using a printer or fed into a computer data field. The readings will generally rise rapidly to their final value reaching its asymptote within 5 minutes (See Figure 10). The highest reading during this period represents the relay's thermal offset voltage. If the relay is well designed this thermal offset will maintain itself over a 24 hour period and longer.

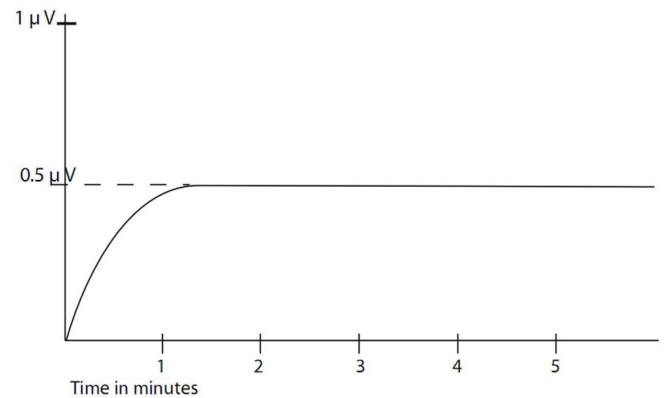

Figure 10. Typical thermal offset voltage curve generated once coil power is applied.

Double Pole Relay Measurement

The offset differential voltage measurement is measured similar to how it is used (described above). When the contacts close, these switch outputs are generally switched into the inputs of a differential amplifier. In this case, a small mass copper shorting lead must be connected across the two output reed contacts. This shorting lead will remain connected throughout the test and represents the input to the differential amplifier. From here the setup is similar to the one pole relay measurement. (See Figure 11). The curve generated is also very similar to that in Figure 10.

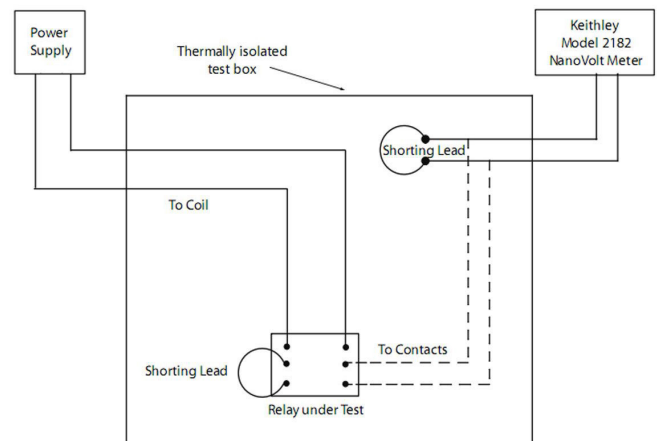

Figure 10. Double pole relay thermal offset voltage measurement setup.

Reducing the Nominal Coil Voltage

Some users take advantage of the natural hysteresis between the operate voltage and the release voltage of the Reed Relay by reducing the nominal voltage to the relay once the relay has been successfully turned on and the contacts are closed. (generally less than 1 ms). Depending upon the characteristics of a 5 volt relay, one may reduce the voltage by one to two volts. Since the power is reduced as the square of the voltage (V^2), the heat is reduced at that same rate. This approach will have a significant reduction in the thermal offset voltage.

Summary

Thermally compensated Reed Relays that reduce any internal thermally produced offset voltages have been in use for several years. Their properties have continued to improve and can represent the best economic solution for a host of expanding electronic applications.

Find out more about our ability to propel your business with our products by visiting www.standexmeder.com or by giving us a hello@standexelectronics.com today! One of our brilliant engineers or solution selling sales leaders will listen to you immediately.

About Standex-Meder Electronics

Standex-Meder Electronics is a worldwide market leader in the design, development and manufacture of standard and custom electro-magnetic components, including magnetics products and reed switch-based solutions.

Our magnetic offerings include planar, Rogowski, current, and low- and high-frequency transformers and inductors. Our reed switch-based solutions include Meder, Standex and OKI brand reed switches, as well as a complete portfolio of reed relays, and a comprehensive array of fluid level, proximity, motion, water flow, HVAC condensate, hydraulic pressure differential, capacitive, conductive and inductive sensors.

We offer engineered product solutions for a broad spectrum of product applications in the automotive, medical, test and measurement, military and aerospace, as well as appliance and general industrial markets.

Standex-Meder Electronics has a commitment to absolute customer satisfaction and customer-driven innovation, with a global organization that offers sales support, engineering capabilities, and technical resources worldwide.

Headquartered in Cincinnati, Ohio, USA, Standex-Meder Electronics has eight manufacturing facilities in six countries, located in the United States, Germany, China, Mexico, the United Kingdom, and Canada.

For more information on Standex-Meder Electronics, please visit us on the web at www.standexmeder.com.

Contact Information:

Standex-Meder Electronics
World Headquarters
4538 Camberwell Road
Cincinnati, OH 45209 USA

Standex Americas (OH)
+1.866.STANDEX (+1.866.782.6339)
info@standexelectronics.com

Meder Americas (MA)
+1.800.870.5385
salesusa@standexmeder.com

Standex-Meder Asia (Shanghai)
+86.21.37820625
salesasia@standexmeder.com

Standex-Meder Europe (Germany)
+49.7731.8399.0
info@standexmeder.com